

		NVIDIA Corporation 3535 Monroe St Santa Clara, CA 95051, USA	
		RIVA TNT2-Pro PCI 16MB SDRAM Production Board - REV C00	
Size	CAGE Code	DWG NO	
City		602-10009-0000	
Scale		Sheet	2 of 8

Friday, January 28, 2000

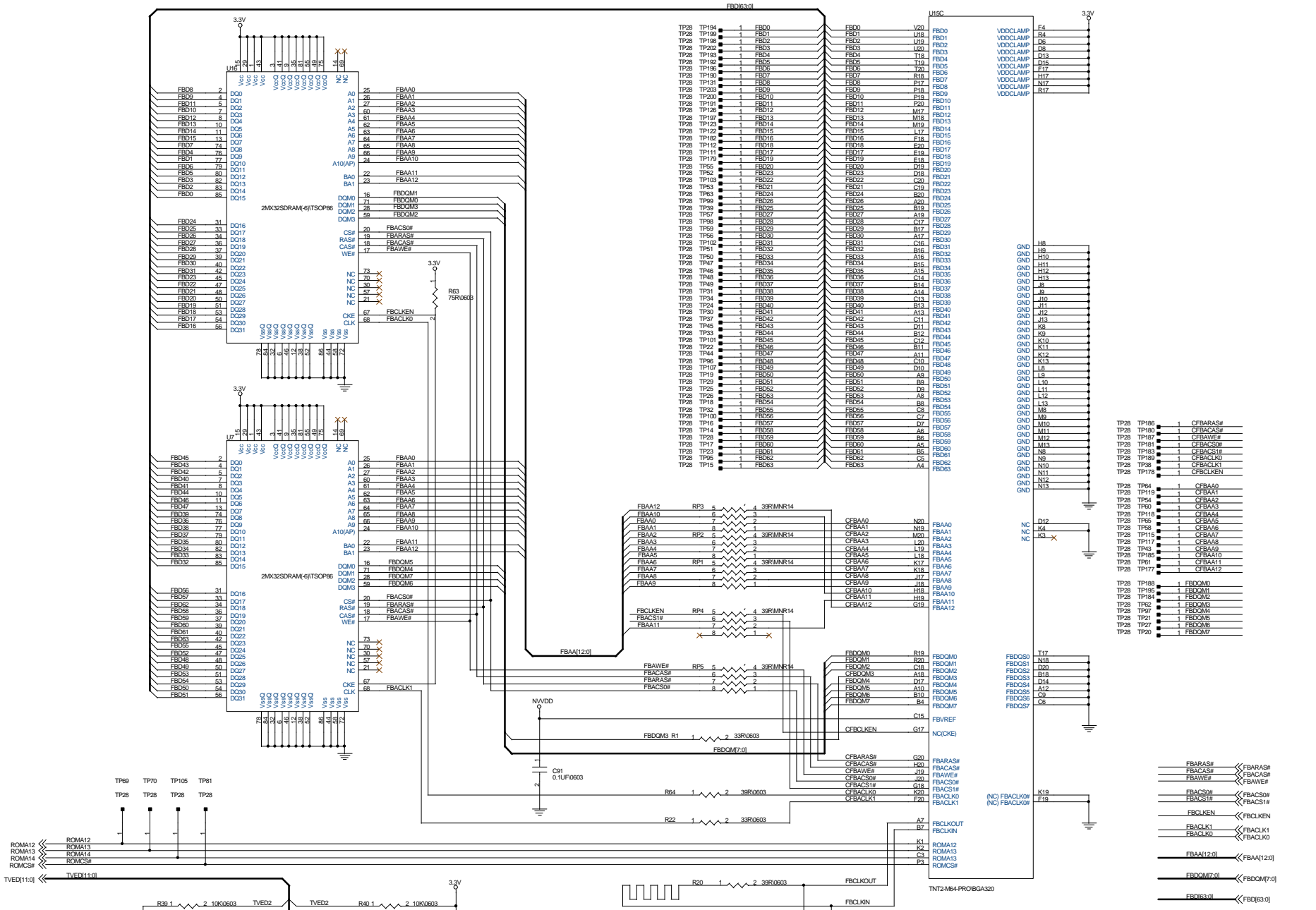

STRAP_RAM_TYPE=0000 : 26x32
 STRAP_RAM_TYPE=0001 : 48x16
 STRAP_RAM_TYPE=0011 : 18x16

THESE RESISTORS ARE INDICATED AS NO STUFF'S IN HIDDEN FILES
 DEPENDING ON THE SELECTED MEMORY CONFIG



NVIDIA Corporation
 3835 Monroé St
 Santa Clara, CA 95051, USA

RIVA TNT2-Pro PCI 16MB SDRAM Production Board - REV C00

Size	CAGE Code	DWG NO	Rev
C		602-10009-0000	000
Scale		Sheet	3 of 8

Friday, January 28, 2000

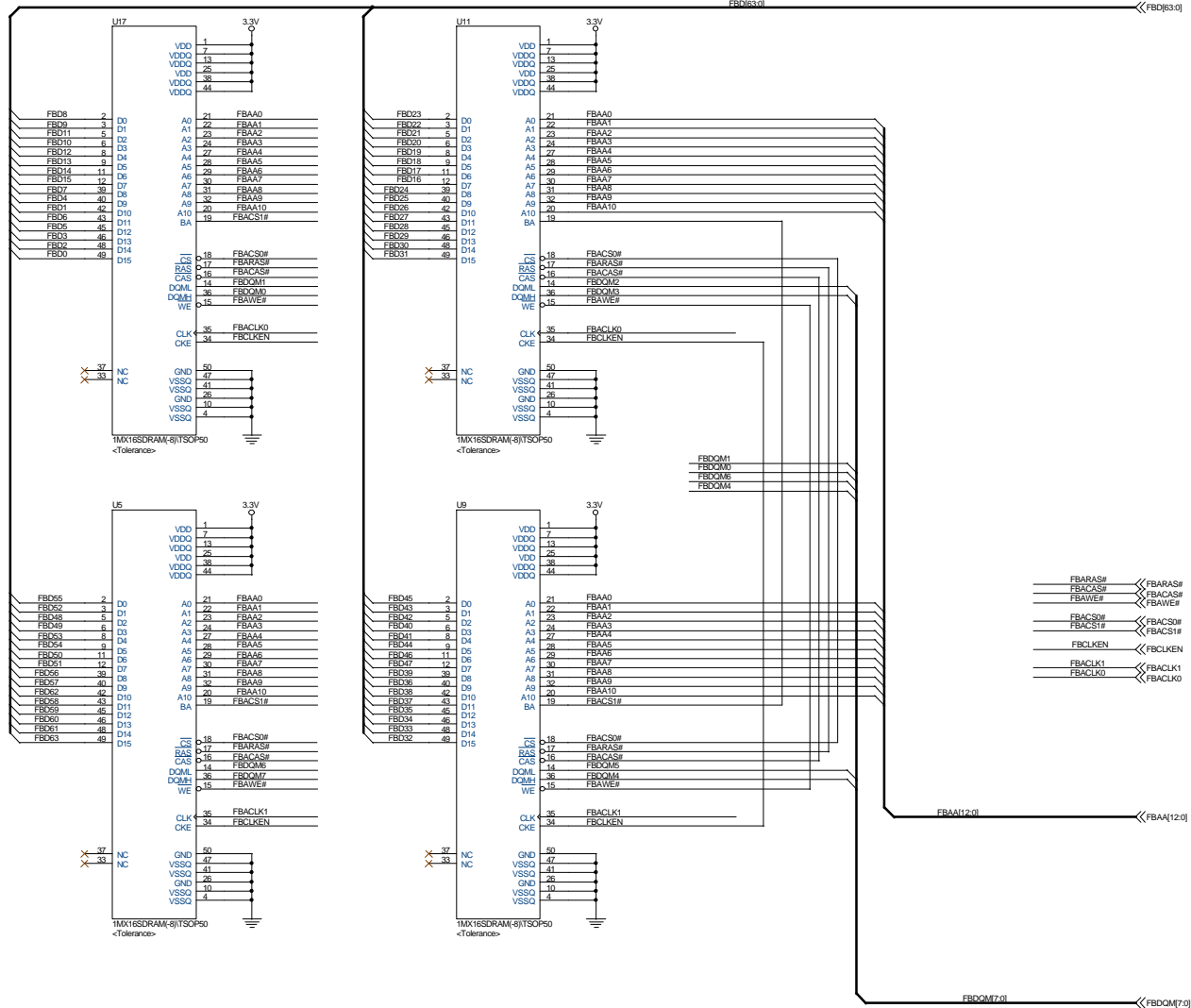

		NVIDIA Corporation 3333 Ruffe St Santa Clara, CA 95051, USA	
		RIVA TNT2-Pro PCI 16MB SDRAM Production Board - REV C00	
Size	C	CAGE Code	DWG NO
Scale			602-10009-0000
Friday, January 28, 2000		Sheet	4 of 8

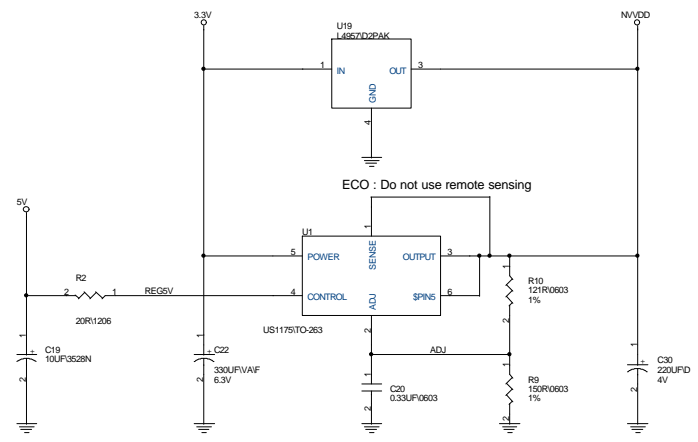
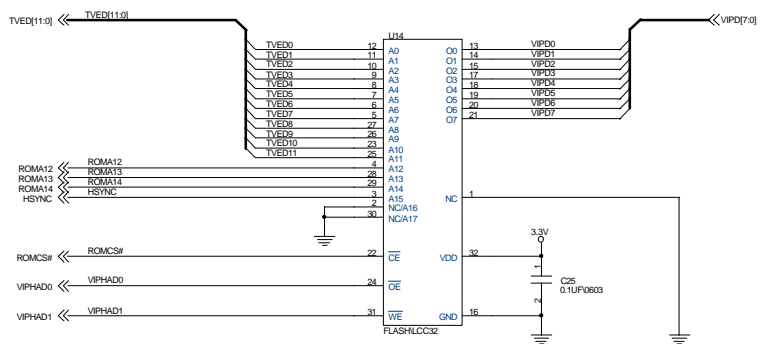

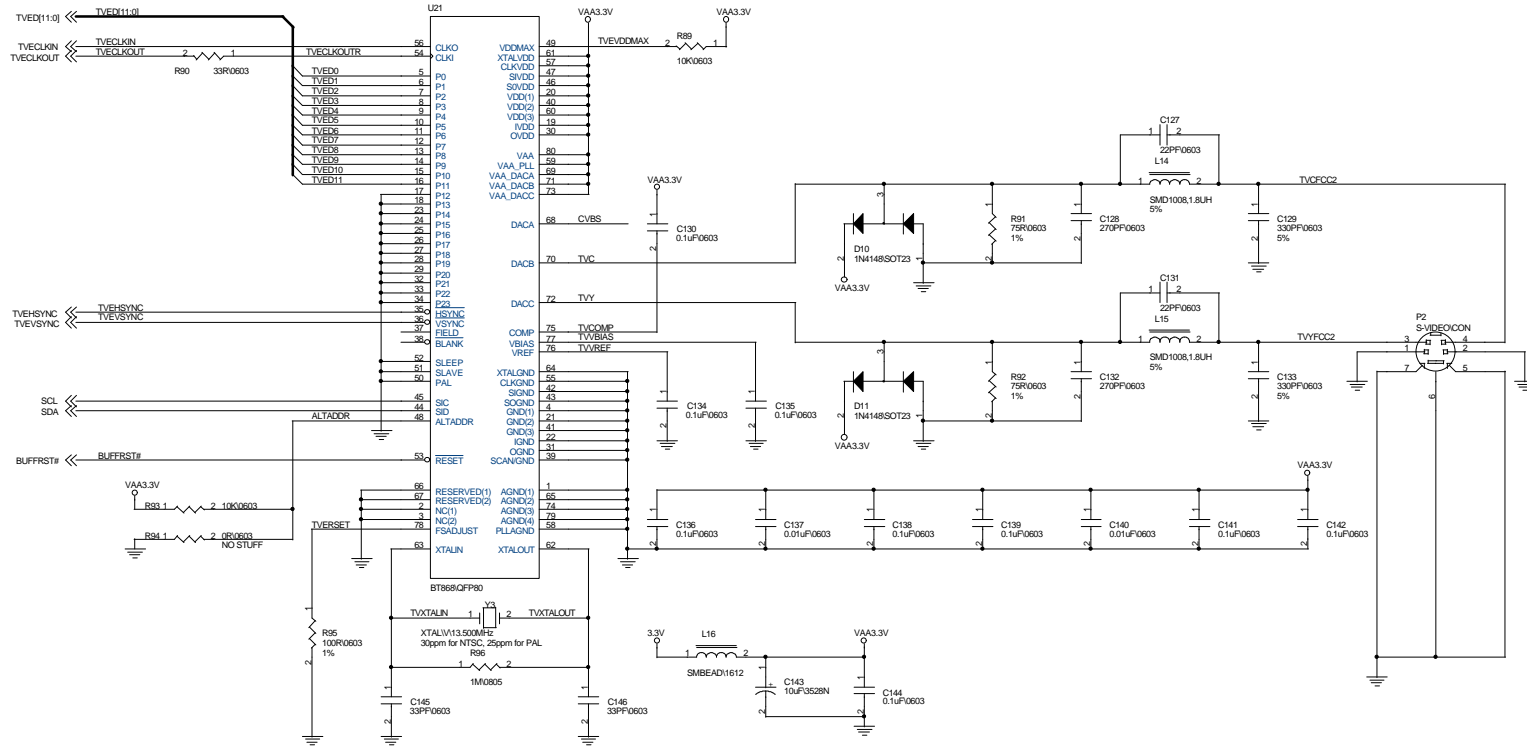

	NVIDIA Corporation 3535 Menlo Rd St Santa Clara, CA 95051, USA		
	RIVA TNT2-Pro PCI 16MB SDRAM Production Board - REV C00		
Size	CAGE Code	DWG NO	Rev
C		602-10009-0000	2000
Scale	Sheet	6	of 8
Friday, January 28, 2000			

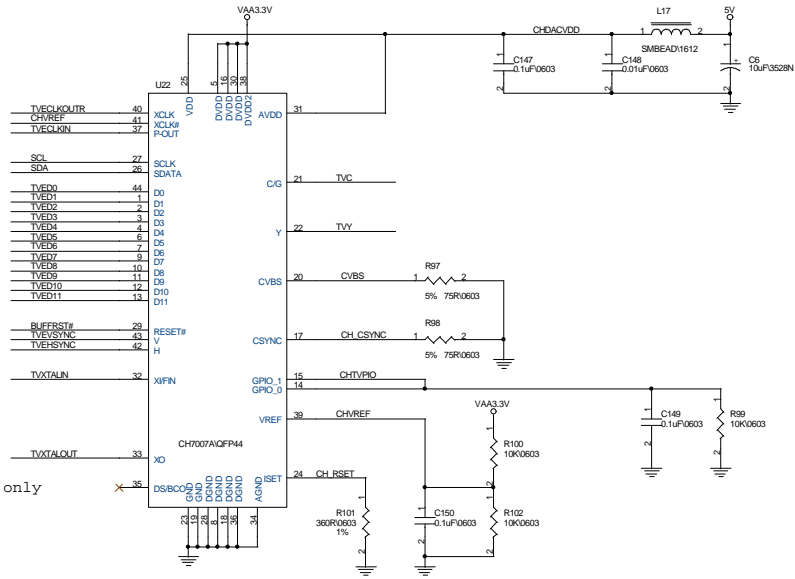

Parts for Chrontel CH7008/8A only



 NVIDIA		NVIDIA Corporation 3535 Monroe St Santa Clara, CA 95051, USA	
		RIVA TNT2-Pro PCI 16MB SDRAM Production Board - REV C00	
Size	CAGE Code	DWG NO	
Scale		602-10009-0000	
Friday, January 28, 2000		Sheet	7 of 8

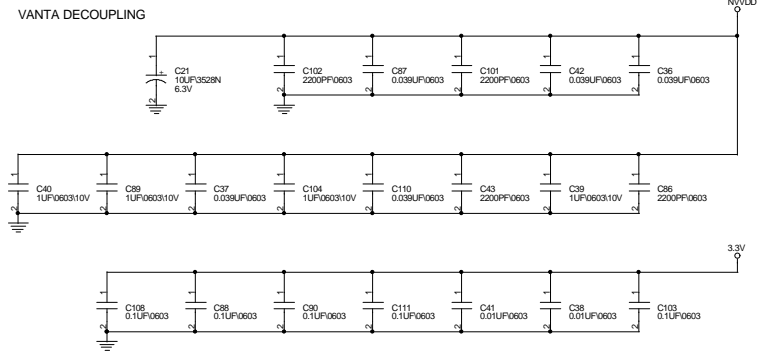
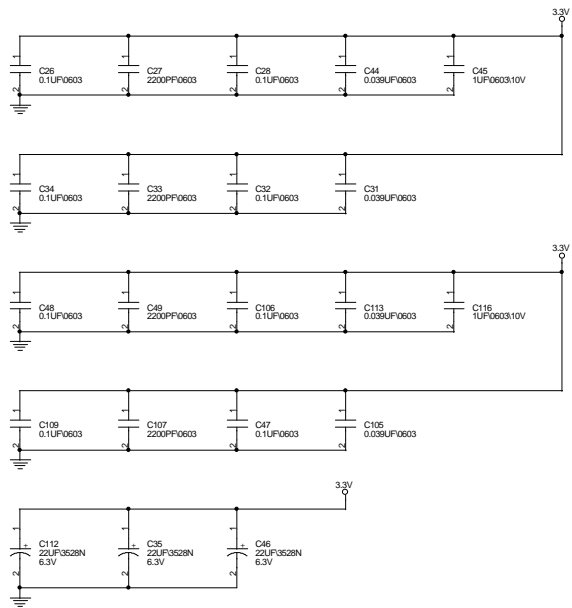

 NVIDIA	NVIDIA Corporation 3535 Menlo Rd St Santa Clara, CA 95051, USA		
	RIVA TNT2-Pro PCI 16MB SDRAM Production Board - REV C00		
Size C	CAGE Code	DWG NO 602-10009-0000	Rev C00
Friday, January 28, 2000	Scale	Sheet 8	of 8